

# OPERATION MANUAL



TB-60



TB-70

## Electric Pipe & Tube Bender

**Models TB-60 & TB-70**

Order Code T606, Order Code T607

*Edition No* :TB-60,70-2

*Date of Issue* :02/2021

**MACHINE DETAILS**

**MACHINE**

PIPE & TUBE BENDER

**MODEL NO.**

**SERIAL NO.**

**DATE OF MANF.**

DISTRIBUTED BY



[www.machineryhouse.com.au](http://www.machineryhouse.com.au)

[www.machineryhouse.co.nz](http://www.machineryhouse.co.nz)

**NOTE:**

This manual is only for your reference. Owing to the continuous improvement of the HAFCO METALMASTER machine, changes may be made at any time without obligation or notice. Please ensure that the local voltage is the same as listed on the specification plate before operating this electric machine.



**NOTE:**

In order to see the type and model of the machine, please see the specification plate, usually found on the back of the machine. See example (Fig.1)

A rectangular specification plate with the HAFCO logo at the top. Below the logo, it says "PRODUCT SPECIFICATION". There are seven rows of labels followed by empty rectangular boxes for input: MODEL:, CAPACITY:, SER. NO:, MFG DATE:, WEIGHT:, VOLTS:, and MOTOR Kw:. At the bottom, it lists the website [www.machineryhouse.com.au](http://www.machineryhouse.com.au) and "Made in China".

FIG.1

**CONTENTS:**

<b>1. GENERAL MACHINE INFORMATION</b>	
1.1 Specifications.....	4
1.2 Accessories Included.....	4
1.3 Identification (TB-60).....	5
1.4 Identification (TB-70).....	6
1.5 Accessory Identification.....	7
<b>2. IMPORTANT INFORMATION</b>	
2.1 General Metalworking Machine Safety.....	8
2.2 Tube and Pipe Bender Safety Procedure.....	11
2.3 Lifting Instructions.....	12
<b>3. SETUP</b>	
3.1 Clean Up.....	13
3.2 Site Preparation.....	13
3.3 Machine Leveling.....	13
3.4 Electrical Installation.....	14
3.5 Checking The Motor Direction on TB-70.....	14
3.6 Full Load Current.....	14
<b>4. OPERATION</b>	
4.1 Bending Capacity.....	15
4.2 Bending Thick-Wall Pipe - Using 2 Rolls.....	16
4.3 Bending Thin Wall Tube - Using Counter Former..	17
4.4 Digital Control Operation.....	18
4.5 F.A.Q.....	22
<b>5. MAINTENANCE</b>	
5.1 Type And Frequency Of Inspections.....	23
5.2 Output Arbor Replacement.....	23
Spare Parts.....	24
Risk Assessment Sheets.....	41

### 1.1 SPECIFICATION

Order Code	T606	T607
MODEL	TB-60	TB-70
Material (Type)	Pipe & Tube	Pipe & Tube
Material Section (Type)	Round	Round
Machine (Type)	Electric	Electric
Round Pipe Range (NB) - Mild Steel (Inch)	1/2" - 1-1/4"	1/2" - 2"
Round Tube Range (OD) - Mild Steel (mm)	25.4 - 51	25.4 - 51
Round Pipe (NB) x Wall Capacity - Mild Steel (Inch)	1-1/4" x 1/8"	2" x 1/8"
Round Tube (OD) x Wall Capacity - Mild Steel (mm)	51 x 2	51 x 3
Round Tube (OD) x Wall Capacity - Aluminium (mm)	51 x 3	51 x 5
Round Tube (OD) x Wall Capacity - Copper, Brass (mm)	51 x 2	51 x 4
Round Tube (OD) x Wall Capacity - Stainless Steel (mm)	38 x 1.6	51 x 2
Centre Line Radius - Maximum (CLR) (Inch/mm)	4 x Former Diameter	4 x Former Diameter
Centre Line Radius - Minimum (CLR) (Inch/mm)	3 x Former Diameter	3 x Former Diameter
Angle Capacity (Deg)	0 - 210°	0 - 210°
Motor Power (kW/hp)	1.1 / 1.5	2.2 / 3
Voltage / Amperage (V/amp)	240 / 10	415/15
Dimensions (mm)	760 x 470 x 590	860 x 615 x 1145
Nett Weight (kg)	140	240

### 1.2 ACCESSORIES INCLUDED

#### T606

Pipe Formers:

1/2" NB x 59.2mm CLR

3/4" NB x 80mm CLR

1" NB x 100.1mm CLR

1-1/4" NB x 127.4mm CLR

Tool box and Instruction Manual

#### T607

Floor stand

Pipe Formers:

1/2" NB x 59.2mm CLR

3/4" NB x 80mm CLR

1" NB x 100.1mm CLR

1-1/4" NB x 127.4mm CLR

Tool box and Instruction Manual

**1.3 IDENTIFICATION (TB-60)**

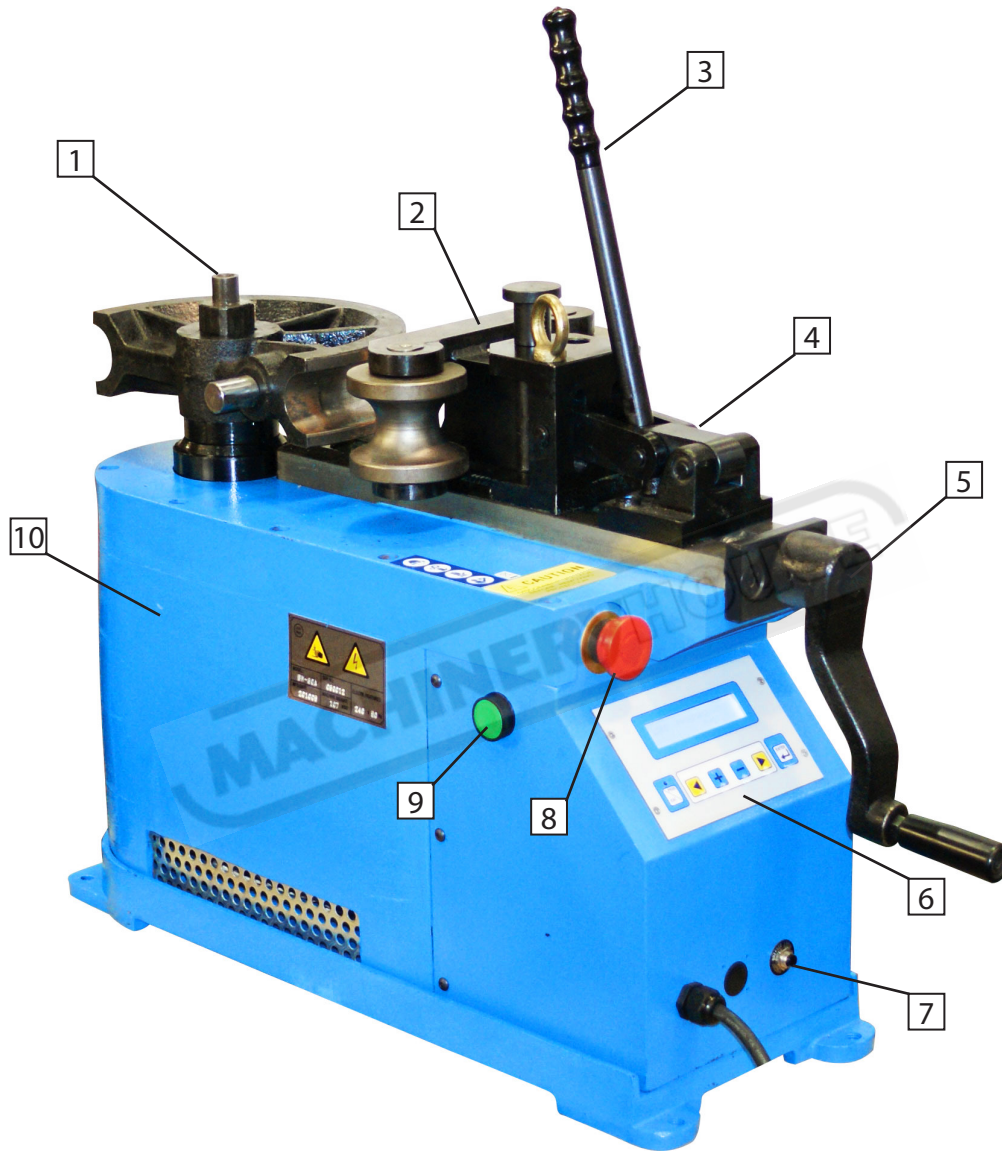

1	Output Drive Arbor For Former	6	Digital Control
2	Guide Roller Support Bracket	7	Overload Reset Button
3	Quick Positioning Lever	8	Emergency Stop Button
4	Quick Positioning Guide Support	9	Power And Cycle Button
5	Guide Support Adjustment Handle	10	Base

**1.4 IDENTIFICATION (TB-70)**



<b>1</b>	Output Drive Arbor For Former	<b>6</b>	Digital Control
<b>2</b>	Guide Roller Support Bracket	<b>7</b>	Motor Speed Selection Switch
<b>3</b>	Quick Positioning Lever	<b>8</b>	Emergency Stop Button
<b>4</b>	Quick Positioning Guide Support	<b>9</b>	Main Isolating Power Switch
<b>5</b>	Guide Support Adjustment Handle	<b>10</b>	Stand

### 1.5 ACCESSORY IDENTIFICATION

The formers supplied with the machine are suitable for bending pipe and are made from cast-iron. Each former includes a material retaining ring to retain the material when bending.

Each former is marked with:

1. Nominal bore pipe size in imperial
2. Centre line bending radius in mm. (CLR)



### PAIR OF ROLLS

A pair of support rolls are supplied with each pipe former and are to be used when bending medium/thick wall pipe. The rolls are held in a carrier then, fitted to the Quick Positioning Guide Support. (Two rolls for each diameter).

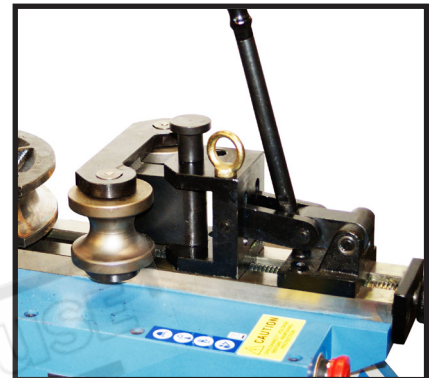

### COUNTER-FORMER (Optional)

The counter former is made from brass and is supplied with the optional tube formers and is used for bending thin-wall tube.

Each counter former is marked with the material diameter in mm/inches, and is supported directly on the Quick Positioning Guide Support.

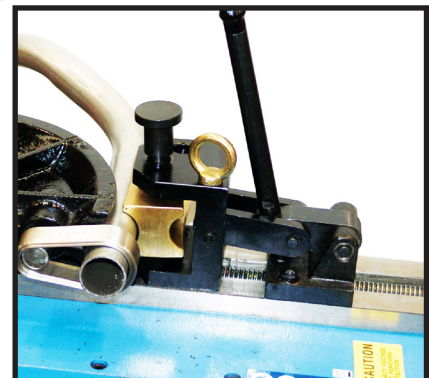

### OPTIONAL FORMER SETS

TBF-S253238 - 25.4, 31.8 & 38.1mm OD Round Cast Steel Tube Former Set.

Suits TB-60 and TB-70 (Order Code T610)

TBF-S51 - 51mm OD Round Tube Cast Steel Former Set.

Suits TB-60 and TB-70 (Order Code T610)



## 2.1 GENERAL METALWORKING MACHINE SAFETY

DO NOT use this machine unless you have read this manual or have been instructed in the use of this machine in its safe use and operation



# WARNING

This manual provides safety instructions on the proper setup, operation, maintenance, and service of this machine. Save this manual, refer to it often, and use it to instruct other operators. Failure to read, understand and follow the instructions in this manual may result in fire or serious personal injury—including amputation, electrocution, or death.

The owner of this machine is solely responsible for its safe use. This responsibility includes, but is not limited to proper installation in a safe environment, personnel training and authorization to use, proper inspection and maintenance, manual availability and comprehension, of the application of the safety devices, integrity, and the use of personal protective equipment.

The manufacturer will not be held liable for injury or property damage from negligence, improper training, machine modifications or misuse.



- ✓ Always wear safety glasses or goggles.
- ✓ Wear appropriate safety footwear.
- ✓ Wear respiratory protection where required.
- ✓ Gloves should never be worn while operating the machine, and only worn when handling the work-piece.
- ✓ Wear hearing protection in areas > 85 dBA. If you have trouble hearing someone speak from one metre (three feet) away, the noise level from the machine may be hazardous.
- ✓ DISCONNECTION THE MACHINE FROM POWER when making adjustments or servicing.
- ✓ Check and adjust all safety devices before each job.
- ✓ Ensure that guards are in position and in good working condition before operating.
- ✓ Ensure that all stationary equipment is anchored securely to the floor.
- ✓ Ensure all machines have a start/stop button within easy reach of the operator.
- ✓ Each machine should have only one operator at a time. However, everyone should know how to stop the machine in an emergency.

**2.1 GENERAL METALWORKING MACHINE SAFETY Cont.**

- ✓ Ensure that keys and adjusting wrenches have been removed from the machine before turning on the power. Appropriate storage for tooling should be provided.
- ✓ Ensure that all cutting tools and blades are clean and sharp. They should be able to cut freely without being forced.
- ✓ Stop the machine before measuring, cleaning or making any adjustments.
- ✓ Wait until the machine has stopped running to clear cuttings with a vacuum, brush or rake.
- ✓ Keep hands away from the cutting head and all moving parts.
- ✓ Avoid awkward operations and hand positions. A sudden slip could cause the hand to move into the cutting tool or blade.
- ✓ Return all portable tooling to their proper storage place after use.
- ✓ Clean all tools after use.
- ✓ Keep work area clean. Floors should be level and have a non-slip surface.
- ✓ Use good lighting so that the work piece, cutting blades, and machine controls can be seen clearly. Position any shade lighting sources so that they do not cause any glare or reflections.
- ✓ Ensure there is enough room around the machine to do the job safely.
- ✓ Obtain first aid immediately for all injuries.
- ✓ Understand that the health and fire hazards can vary from material to material. Make sure all appropriate precautions are taken.
- ✓ Clean machines and the surrounding area when the operation is finished.
- ✓ Use proper lock out procedures when servicing or cleaning the machines or power tools.

**DO NOT**

- × Do not distract an operator. Horseplay can lead to injuries and should be strictly prohibited.
- × Do not wear loose clothing, gloves, necktie's, rings, bracelets or other jewellery that can be come entangled in moving parts. Confine long hair.
- × Do not handle cuttings by hand because they are very sharp. Do not free a stalled cutter without turning the power off first. Do not clean hands with cutting fluids.
- × Do not use rags or wear gloves near moving parts of machines.
- × Do not use compressed air to blow debris from machines or to clean dirt from clothes.
- × Do not force the machine. It will do the job safer and better at the rate for which it was designed.



***BEFORE OPERATING ANY MACHINE, TAKE TIME TO READ AND UNDERSTAND ALL SAFETY SIGNS AND SYMBOLS. IF NOT UNDERSTOOD SEEK EXPLANATION FROM YOUR SUPERVISOR.***

## 2.1 GENERAL METALWORKING MACHINE SAFETY Cont.

HAZARDS ASSOCIATED WITH MACHINES include, but are not limited to:

- Being struck by ejected parts of the machinery
- Being struck by material ejected from the machinery
- Contact or entanglement with the machinery
- Contact or entanglement with any material in motion

Health Hazards (other than physical injury caused by moving parts)

- Chemicals hazards that can irritate, burn, or pass through the skin
- Airborne items that can be inhaled, such as oil mist, metal fumes, solvents, and dust
- Heat, noise, and vibration
- Ionizing or non-ionizing radiation (X-ray, lasers, etc.)
- Biological contamination and waste
- Soft tissue injuries (for example, to the hands, arms, shoulders, back, or neck) resulting from repetitive motion, awkward posture, extended lifting, and pressure grip)

Other Hazards

- Slips and falls from and around machinery during maintenance
- Unstable equipment that is not secured against falling over
- Safe access to/from machines (access, egress)
- Fire or explosion
- Pressure injection injuries from the release of fluids and gases under high pressure
- Electrical Hazards, such as electrocution from faulty or ungrounded electrical components
- Environment in which the machine is used (in a machine shop, or in a work site)



***MACHINES ARE SAFEGUARDED TO PROTECT THE OPERATOR FROM INJURY OR DEATH WITH THE PLACEMENT OF GUARDS. MACHINES MUST NOT BE OPERATED WITH THE GUARDS REMOVED OR DAMAGED.***

## 2.2 TUBE & PIPE BENDER SAFETY PROCEDURE

**DO NOT use this machine unless you have been instructed in its safe use and operation and have read and understood this manual**



*Safety glasses must be worn at all times in work areas.*



*Long and loose hair must be contained or restrained*



*Appropriate protective footwear with substantial uppers must be worn*



*Coveralls, protective clothing, or a workshop apron, is recommended*



*Rings and jewellery must not be worn when operating the machine.*



*DO NOT wear large leather gloves when operating this machinery*

### PRE-OPERATIONAL SAFETY CHECKS

1. Working parts should be well lubricated and free from rust and dirt.
2. All working parts should be checked to ensure they are in good working order. If faulty the machine must be repaired before operating.
3. Ensure the work area is clear of scrap material, off cuts and tools.
4. The work area around the machine must be free of items that may cause a slip or trip hazards.
5. Make sure bystanders and other workers are clear of the bending pipe before operating.
6. If using an extension lead make sure that it is protected from damaged by passing traffic, wet areas, or chemical residue.

### OPERATIONAL SAFETY CHECKS

1. Strictly only one operator is to operate this tube and pipe bender and when necessary with a helper to assist in supporting the pipe or tube, when bending long lengths.
2. Never use any tube or pipe bender to bend beyond the capacity of the machine.
3. Ensure that both hands are positioned away from any possible pinch point
4. Particular preparation and caution is to be observed when bending long lengths of pipe or tube.
5. This pipe and tube bender is not fitted with any safety beams or electronic sensors to detect any hazardous circumstances. The operator must be attentive to what is happening both at the bend and at the ends of the material
6. Never leave the machine in operational mode while unattended.

### POTENTIAL HAZARDS

- Entanglement and entrapment
- Pinch, crush and squash
- Electrical components
- Striking and lifting injuries
- Manual handling
- Eye injury

**2.3 LIFTING INSTRUCTIONS**

On the day that the machine arrives, make sure that a crane with sufficient capacity is available to unload the machine from the vehicle. Ensure access to the chosen site is clear and that doors and ceilings are sufficiently high and wide enough to receive the machine. To handle the machine, the slings should be positioned so the machine is level when lifted. When using slings please take note of the sling angle and the loads that apply

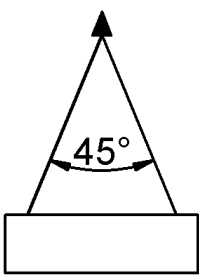

FIG 2.1.

When the slings are at a 45° angle then each sling is carrying the equivalent of 50% of load weight. (Fig.2.1).

When the slings are at a 90° angle then each sling will have a weight equal to 75% of the load on each sling. (Fig 2.2)

Note! The manufacturer recommends not to exceed 90° angle

FIG 2.2

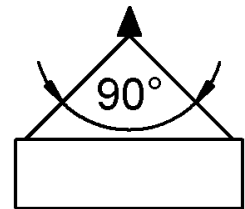

**LIFTING POINTS**

When lifting the machine only certified lifting slings should be used. The load centre of the machine must be set using the lifting eyebolt to be screwed into the top casing. Ensure that when lifting, the machine does not tip over. Turn the Quick Positioning Guide Support adjustment aandle to level the machine. (Fig.2.3)

**NOTE: THE LIFTING EYEBOLT MUST BE REMOVED BEFORE OPERATING AS IT INTERFERES WITH THE WORKING SPACE OF THE MACHINE.**



FIG.2.3

**Optional Stand For TB-60 (Fig.2.4)**

Model TBS-4260  
Suits T606 Pipe and Tube Benders  
Order Code T603



FIG.2.4

### 3. SETUP

#### 3.1 CLEAN - UP

The unpainted surfaces of the machine have been coated with a waxy oil to protect them from corrosion during shipment. Remove the protective coating with a solvent cleaner or a citrus based degreaser.

Optimum performance from your machine will be achieved when you clean all moving parts or sliding contact surfaces that are coated with rust prevented products.

It is advised to avoid chlorine based solvents, such as acetone or brake parts cleaner, as they will damage painted surfaces and strip metal should they come in contact. Always follow the manufacturer's instructions when using any type of cleaning product.

#### 3.2 SITE PREPARATION

When selecting the site for the machine, consider the largest size of workpiece that will be processed through the machine and provide enough space around the machine for operating the machine safely. Consideration should be given to the installation of auxiliary equipment. Leave enough space around the machine to open or remove doors/covers as required for the maintenance and service as described in this manual.

It is recommended that the machine is anchored to the floor to prevent tipping or shifting. It also reduces vibration that may occur during operation.

#### OPTIONS FOR MOUNTING

##### TB-60

The machine is best mounted on a bench or a stand that is mounted on a concrete slab.

##### TB-70

The machine is best mounted on a concrete slab.

Masonry anchors with bolts is the best way to anchor machinery, because the anchors sit flush with the floor surface, making it easy to unbolt and move the machine later, if needed. (Fig. 3-1)

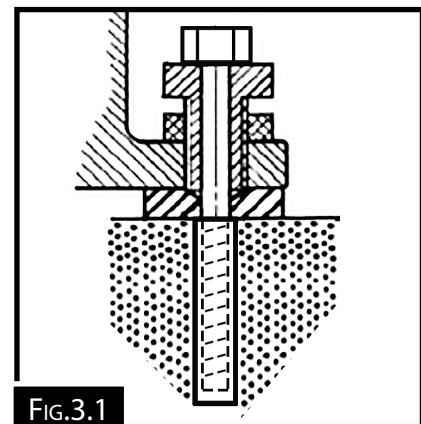

FIG.3.1

#### 3.3 MACHINE LEVELING

To set your machine up so that it operates to optimum performance, apply the following procedure

After your machine has been anchored, it then needs to be leveled. Loosen the hold down bolts and place a level on the surface of the working table. Metal shims need to be placed under the base of the machine, both sides of the hold down bolt until level. Once level then tighten the hold down bolts. (Fig. 3.1).

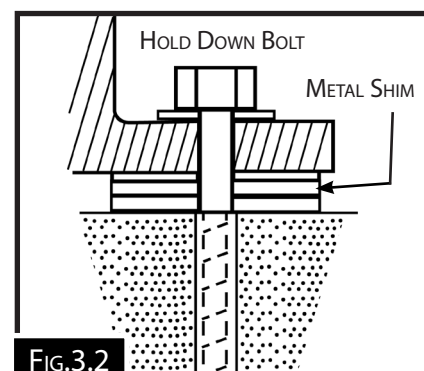

FIG.3.2

### 3.4 ELECTRICAL INSTALLATION

Place the machine near an existing power source. Make sure all power cords are protected from traffic, material handling, moisture, chemicals, or other hazards. Make sure there is access to a means of disconnecting the power source. The electrical circuit must meet the requirements for the voltage listed on the specification plate.

**NOTE : THE USE OF AN EXTENSION CORD IS NOT RECOMMENDED AS IT MAY DECREASE THE LIFE OF ELECTRICAL COMPONENTS ON YOUR MACHINE.**

### 3.5 CHECKING THE MOTOR DIRECTION ON TB-70

HAFCO METALMASTER machines are supplied wired ready to run. Check the specification plate on the machine to confirm the correct voltage of the power supply.

The machine must be connected by a qualified and licensed electrician. Warranty could be void if it is found that the connection was not carried out by a qualified electrician.

Once connected, check that the direction of the bending action is the correct direction. If the direction is incorrect, isolate the machine and make changes to the wiring

### 3.6 FULL-LOAD CURRENT RATING

The full-load current rating is the amperage a machine draws when running at 100% of the output power. Where machines have more than one motor, the full load current is the amperage drawn by the largest motor or a total of all the motors and electrical devices that might operate at one time during normal operations.

Full-Load Current Rating for these machine can be found on the specification plate.

It should be noted that the full-load current is not the maximum amount of amps that the machine will draw. If the machine is overloaded, it will draw additional amps beyond the full-load rating and if the machine is overloaded for a long period of time, damage, overheating, or fire may be caused to the motor and circuitry.

This is especially true if connected to an undersized circuit or a long extension lead. To reduce the risk of these hazards, avoid overloading the machine during operation and make sure it is connected to a power supply circuit that meets the requirements.



## 4 OPERATION

**NOTE:**

\* *Cast-iron formers can be used either with the counter formers or the two roll assemble. For tube bending better results are achieved with the counter formers.*

### 4.1 BENDING CAPACITY

This HAFCO METALMASTER machine must be used according to the specifications described in the following tables. The machine must not be used beyond its capacity.

#### TB-60 BENDING CAPACITY

Type	Material Type	Diameter (Inch/mm)	Wall Thickness (Inch/mm)	CLR
Round Pipe (NB)	Mild Steel	1.1/4"	1/8"	127.4
Round Tube (OD)	Mild Steel	51.0	2.0	195
Round Tube (OD)	Aluminium	51.0	3.0	195
Round Tube (OD)	Copper or Brass	51.0	2.0	195
Round Tube (OD)	Stainless Steel	38.1	1.6	152

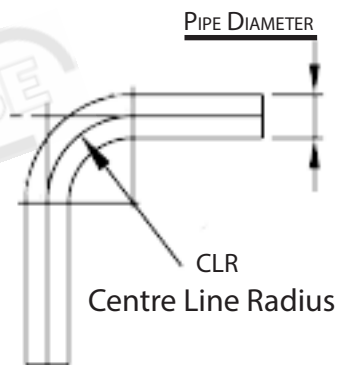

**FIG.4.1**

#### TB-70 BENDING CAPACITY

Type	Material Type	Diameter (Inch/mm)	Wall Thickness (Inch/mm)	CLR
Round Pipe (NB)	Mild Steel	2"	1/8"	203.2
Round Tube (OD)	Mild Steel	51.0	3.0	195
Round Tube (OD)	Aluminium	51.0	5.0	195
Round Tube (OD)	Copper or Brass	51.0	4.0	195
Round Tube (OD)	Stainless Steel	51.0	2.0	195

**FIG.4.2**

#### 4.2 BENDING THICK-WALL PIPE-USING 2 ROLLS

This method is designed to bend mild steel pipe with wall thickness larger than 1.6mm and as listed in the bending tables. (Fig.4.1 and Fig.4.2)

The bending process starts with loading the pipe into the machine and clamping it between two rollers mounted on the Quick Positioning Guide Support and the forming die, then rotating the former.

##### To set up the machine:

1. DISCONNECT THE MACHINE FROM THE POWER
2. Turn the drive arbor (G in Fig.4.4) anticlockwise till the rotation is at the end of the stroke.
3. Select the desired former and place the former over the square drive arbor, making sure that calibration line on the former matches the calibration line on the arbor.
4. Locate the special roll frame body (D) and place the matching rolls (E) in the frame and secure them by inserting the pins (F) through the guide body and rolls. Secure the pins (F) to the frame with 2 screws (C).
5. Place the complete roll frame body in the Quick Positioning Guide Support (A) and fix it with the pin (B).
6. Move the quick-positioning lever (N in Fig.4.5) of the Quick Positioning Guide Support away from the former, and into the locked position.
7. Load the pipe in the machine and using the handle at the end of the machine, move the rolls against the pipe, making sure there is no play between the former, pipe and rolls.
8. Place the corresponding retaining ring (I in Fig.4.5) around the pipe and on to the drive pin (H in Fig.4.4) on the former.



FIG.4.3

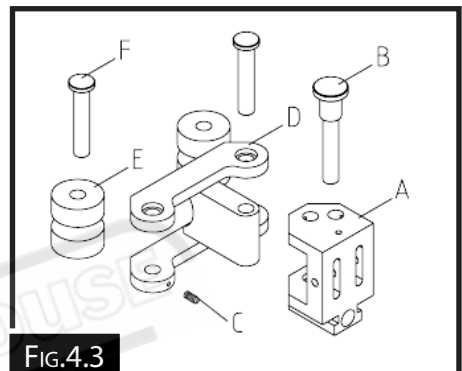

FIG.4.3

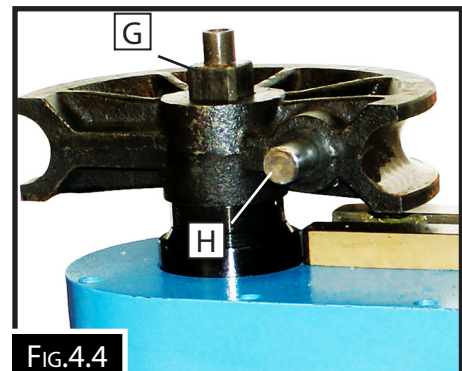

FIG.4.4

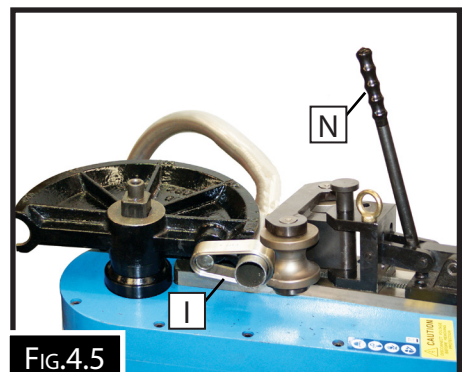

FIG.4.5



**PINCH POINT WARNING:**  
**KEEP FINGERS AND HANDS CLEAR OF ROLLS**  
**AND FORMER WHEN OPERATING**

### 4.3 BENDING THIN WALL TUBE - USING COUNTER FORMER (Optional)

This method is designed to bend thin wall tube with wall thickness no larger than 1.6mm and as listed in the bending tables. (Fig.4.1 and Fig.4.2)

The bending process starts with loading the tube into the machine and clamping it between the counter former mounted on the Quick Positioning Guide Support and the forming die, then rotating the former.

#### To set up the machine:

1. DISCONNECT THE MACHINE FROM THE POWER
2. Turn the drive arbor (G in Fig.4.4) anticlockwise till the rotation is at the end of the stroke.
3. Select the desired former and place the former over the square drive arbor, making sure that calibration line marked "0" on the former matches the calibration line mark "0" on the arbor.
4. Place the counter former (J in Fig.4.7) on the Quick Positioning Guide Support "A" using the pin "B", which needs to be secured with the grub screw "K" which is found in the Quick Positioning Guide Support in front of the pin "B".
5. Move the Quick Positioning Guide Support lever (N in Fig.4.6) of the quick-positioning guide support away from the former, and into the locked position.
6. Load the tube in the machine and using the handle at the end of the machine, move the counter former against the tube, making sure there is no play between the former, tube and counter former.
7. Place the corresponding retaining ring (M in Fig.4.8) around the tube and on to the drive pin (L in Fig.4.8) on the former.

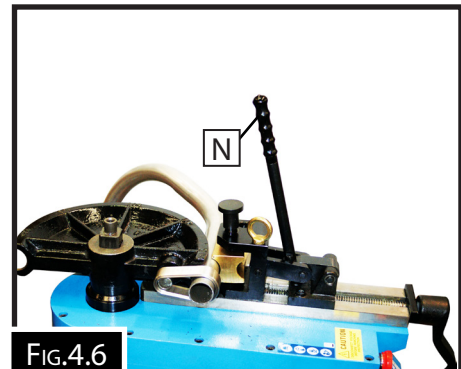

FIG.4.6

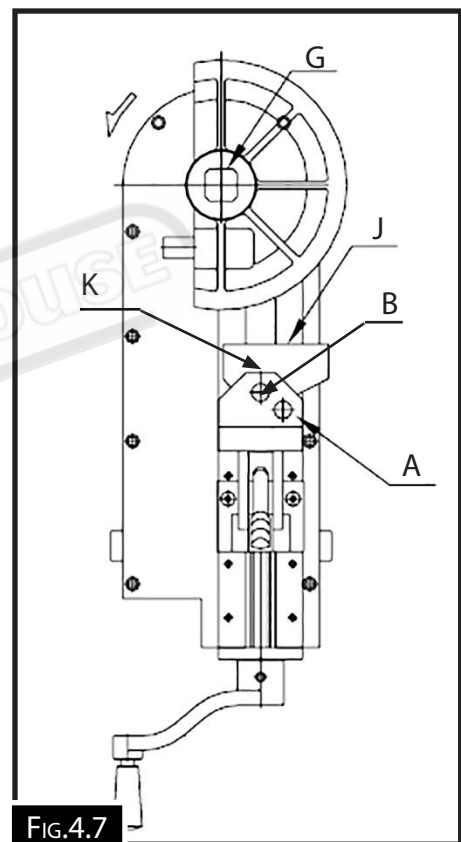

FIG.4.7

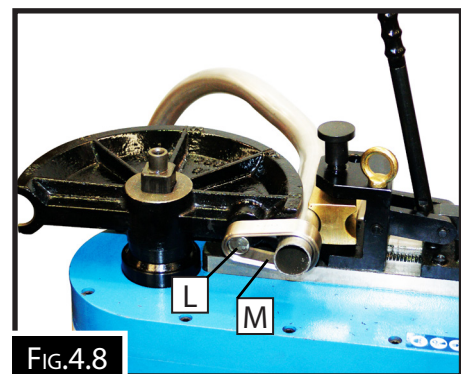
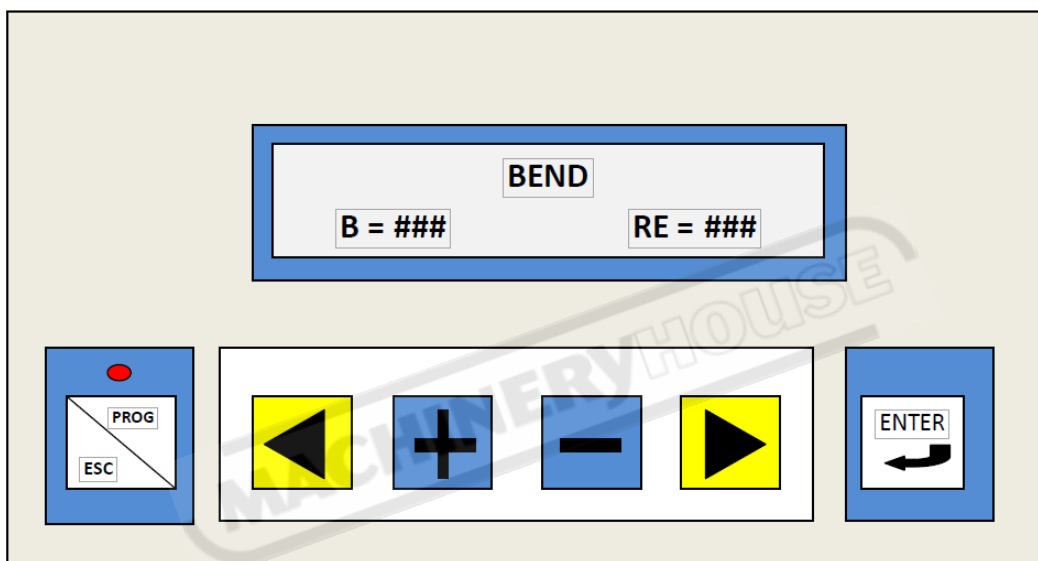

FIG.4.8

#### 4.4 DIGITAL CONTROL OPERATION

The bending action of the machine, is controlled by a programmable display control unit that allows for up to 50 programs to be stored with up to 9 bends in each program.. Listed below is the steps to programing the digital control.

- Ensure emergency stop is released ( twist clockwise)
- Connect the machine to the power supply and turn the machine ON.
- The Screen will come up similar to below (with Numbers instead of ###)



#### SINGLE BEND

A bend is made up of a "Bend Angle" and a "Recovery Angle" (or "over bend" for spring of work-piece)



Depending on the type of material, wall thickness etc, the "RE" setting will be different and will have to be adjusted as needed by operator.

"B"= "the bend angle you want to do"



"RE" = "the extra angle the machine will go over the B setting" This will have to be worked out from trial and error and it is suggested a list be kept to refer to for future similar bends.

#### 4.4 DIGITAL CONTROL OPERATION Cont.

##### TO SET A SINGLE BEND

Press the  arrow once. ("B", angle can be changed) see flashing number on screen.

Press the "+" or "-" button to change number as needed.



Press  or  arrow to select digit to change.

When it is set correctly press "ENTER" to set.

To change the "RE" "Recovery Angle" or over bend!

Press the  arrow once ( bend angle can be changed) see flashing number,

Press the "+" or "-" button to change number as needed.

Press  or  arrow to select digit to change.

When it is set correctly press "ENTER" to set.

##### TO PROCESS A BEND

1. With correct formers and dies fitted, place pipe/tube in position as needed ensuring the retaining ring is well fitted over hook pin on bending die
2. Ensure the Quick Positioning Guide Support lever is in the locked position (to rear of machine)
3. Wind vice handle clockwise to lock tube/bar firmly in place.
4. Check that the movement and bending of the workpiece will not interfere with anything in the surrounding area.
5. With two hands, press simultaneously the left hand and right hand green buttons found on the side of the machine body and hold the buttons in until bending is complete, (Fig.4.9)  
The display will count up to total of the bend angle (B+RE) and when fingers are released the bending arbour will return to "0" ready for next bend.
6. Check angle bent and if more needed reset "RE" and re-bend.
7. The bending die will remain where it finished and after release of the workpiece it will have to be returned to home position by hand before the next work piece can be added. .

**NOTE:** Releasing one or both of the buttons while bending will bring up "INTERRUPT" on the screen. To continue, press both buttons again. Or remove workpiece and continue to full bend to allow bending arbour to return to "Zero point" automatically.

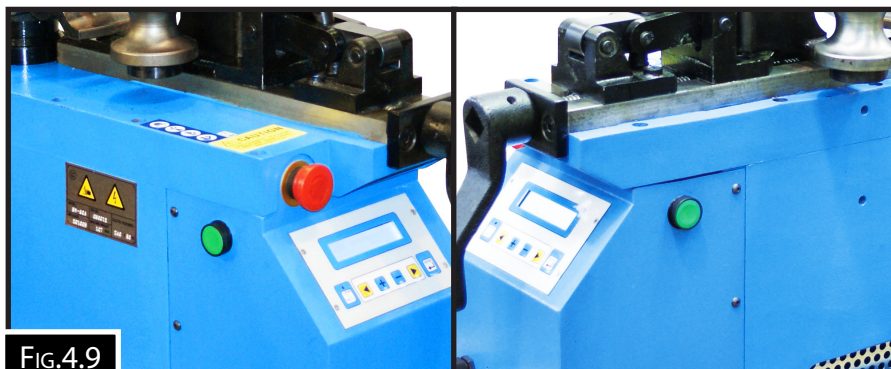



FIG.4.9

#### 4.4 DIGITAL CONTROL OPERATION Cont.

##### ENTERING INTO PROGRAMMED BENDS

Press "Prog/ESC" button. A RED light above this button will go on and the screen will show "LIST BEND"



Press  arrow and the screen will show "LIST PROGRAM"

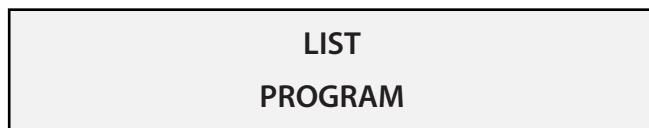

Press the "ENTER" button and the screen will show

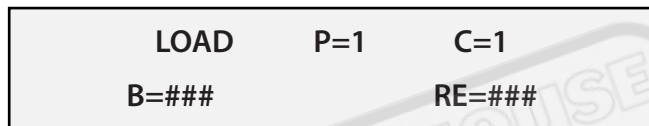



"P" is the program number. Pressing the  arrow will count up to 50 programs.

Pressing the  arrow will count back down.

"C" is the number of the bends in each program (1 to 9)

##### EDITING A PROGRAM

Enter into program mode as above

Select the number of the "PROGRAM" or bend you wish to edit by pressing the  or  arrow  
Then press "ENTER" Button

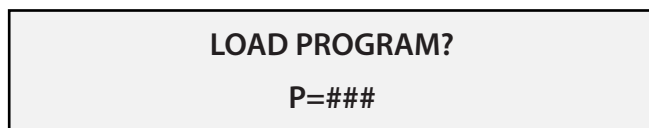



Press "ENTER" again, this will allow entry into the program to Run it or Edit it.

To Edit, press the "+" or "-" button to select the bend number in the program to be changed.

When the correct program has been selected, Press the  arrow once to change the bend angle. (see flashing number.)

Press the "+" or "-" button to change the number as needed.



Press  or  arrow to select digit to change.

When it is set correctly press "ENTER" to set.

To change the "RE" "Recovery Angle" or over bend.

Press the  arrow once to change the over bend angle. (see flashing number.)

Press the "+" or "-" button to change the number as needed.

Press  or  arrow to select digit to change.

When it is set correctly press "ENTER" to set.

#### 4.4 DIGITAL CONTROL OPERATION Cont.

##### TO RUN A PROGRAM

Select the number of the "PROGRAM" or bend you wish to edit by pressing the ◀ or ▶ arrow, Then press the "ENTER" Button

LOAD PROGRAM?  
P=###

Press "ENTER" again, this will put you into the program to Run it or Edit it.

##### To Run the Program selected

1. With correct formers and dies fitted, place pipe/tube in position as needed ensuring the retaining ring is well fitted over hook pin on bending die.
2. Ensure the Quick Positioning Guide Support lever is in the locked position (to rear of machine )
3. Wind vice handle clockwise to lock tube/pipe firmly in place.
4. Check that the movement and bending of the workpiece will not interfere with anything in the surrounding area.
5. With two hands, press simultaneously the left hand and right hand green buttons found on the side of the machine body and hold the buttons in until bending is complete, (Fig.4.9) The display will count up to total of the bend angle (B+RE) and when fingers are released the bending arbour will return to "0" ready for next bend.
6. Release tube/pipe by pulling the top quick release lever forward
7. Reposition tube/pipe as needed for the second bend if programmed. Then re-lock the tube/pipe in place.
8. With two hands, press simultaneously the left hand and right hand buttons and hold the buttons in until bending is complete,
9. Repeat above as needed depending on number of bends in the program.
10. To continue, press both buttons again. Or remove workpiece and continue to full bend to allow bending arbour to return to "Zero point" automatically.

**NOTE: RELEASING ONE OR BOTH OF THE BUTTONS WHILE BENDING WILL BRING UP "INTERRUPT" ON THE SCREEN.**

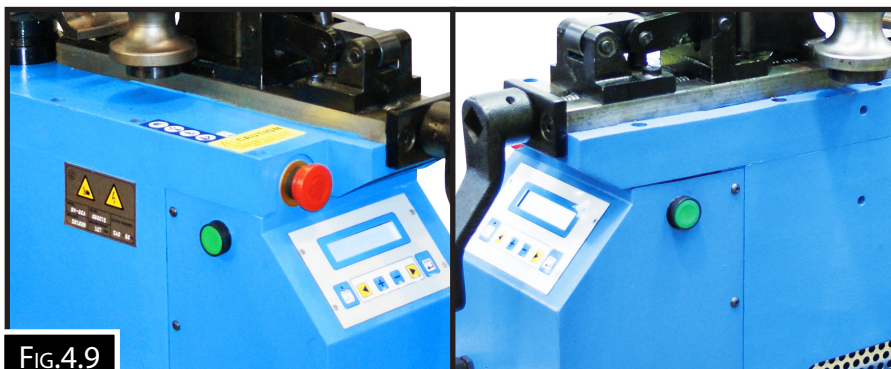

FIG.4.9

**F.A.Q****Will the bender consistently repeat bends the same.**

*When repetition bending the Same ( Material, Diameter & Angle) you can achieve a 0.1 degree of tolerance. Once the Angle and "RE" has been set. Ensure that between bends you only loosen the Quick Acton lever without adjusting the hand wound screw.*

**Will all grades of steel bend the same.**

*No. ("RE" or Spring back)varies for different types of steel i.e. Mild Steel is less than that used for Stainless.*

**How do I stop thin Wall Tubing getting crushed.**

*When wall thickness is below 2mm a "Counter Former Die" must be used, also it must be lubricated with a free flowing thin lubricant such as Pipe/Tube Bendng Lube (Order Code B8119)*

**How do I stop stainless tube getting "Wrinkles" in it?**

*Bending Stainless Steel requires a lot of pressure on the "Counter Former Die"; if not enough pressure a rippling effect will appear on the inside of the tube.*

**NOTE; When Bending ERW Tube, only require light pressure as will squash the tube wall.**

**When I use a "Counter Former Die" the tube ends up with scratches on it.**

*If scratch marks appear where the "counter former die" is picking up on the tube and scratching it, use 1200 wet and dry on the Bronze counter former which will remove these scratches. Also ensure lubricate in used when bending.*

**Can I use the "RE" angle on the same tube and size for different bend angles?**

*No. You will have to calculate the "RE" for each angle even on the same tube and if you want to bend a series on different bends, the accuracy would be approx 0.7 degree.*

**5. MAINTENANCE**

**⚠ WARNING**

*Before maintaining or cleaning the machine, turn off the circuit breaker, or disconnect the machine from the power supply. Post a sign to inform other workers that the machine is under maintenance.*

For optimum performance from the machine, it is important that the machine is well lubricated and maintain. Follow the maintenance schedule listed in the following section and refer to any specific instructions given.

**5.1 TYPE AND FREQUENCY OF THE INSPECTIONS**

DESCRIPTION	FREQUENCY
Cleaning and lubrication of the guide's support	Daily
Whole cleaning from the dust etc.	Weekly
Grease where indicated	Weekly
Cable's condition	Daily

The gear box, should be opened every 1000 hours of operation for thorougher cleaning and replacement of the grease with a heavy duty grease.

**5.2 OUTPUT ARBOR REPLACEMENT**

Verify the alignment of the output arbor every 50 hours, by turning the arbor with the motor. The maximum agreed wobble is 0.5mm. When above this, then replace the arbor.

**To Replace The Arbor:**

1. DISCONNECT THE MACHINE FROM THE POWER SUPPLY
2. Insert the hex. key supplied with the machine into the outlet arbor and unscrew the bolt (M14x45) holding the arbor. (Fig.5.1)
3. Clean thoroughly the end of the arbor and the mating surface.
4. Insert the new arbor, making sure that the gear teeth on the arbor is in line with the teeth on the drive.
5. Insert the screw into the top of the abor and with the hex key tighten the screw.
6. Rotate the arbor and check the "run out" of the arbor.

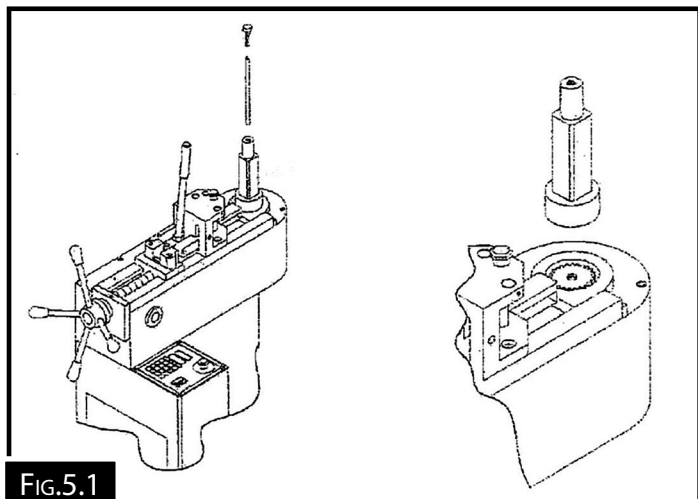

**Fig.5.1**

**NOTE: SHOULD YOU FIND THAT THIS PROCESS IS BEYOND YOUR CAPABILITY THEN CONTACT YOUR LOCAL SERVICE TECHNICIAN**

# SPARE PARTS SECTION

## Electric Pipe & Tube Bender

### Models TB-60 & TB-70

Order Code T606, Order Code T607

*Edition No* :TB-60,70-2

*Date of Issue* :02/2021

The following section covers the spare parts diagrams and lists that were current at the time this manual was originally printed. Due to continuous improvements of the machine, changes may be made at any time without notification.

#### HOW TO ORDER SPARE PARTS

1. Have your machines **model number, serial number & date of manufacture** on hand, these can be found on the specification plate mounted on the machine
2. A scanned copy of your parts list/diagram with required spare part/s identified
3. Go to [www.machineryhouse.com.au/contactus](http://www.machineryhouse.com.au/contactus) and fill out the inquiry form attaching a copy of scanned parts list.

#### CONTENTS

Digital Control Sequence.....	25
TB-60 Electrical Diagram (240volt).....	26
TB-60 Spare Parts Diagram.....	28
TB-60 Spare Parts List.....	29
TB-70 Electrical Diagram (415volt).....	32
TB-70 Spare Parts Diagram.....	36
TB-70 Spare Parts List.....	37

**DIGITAL CONTROL SEQUENCE**

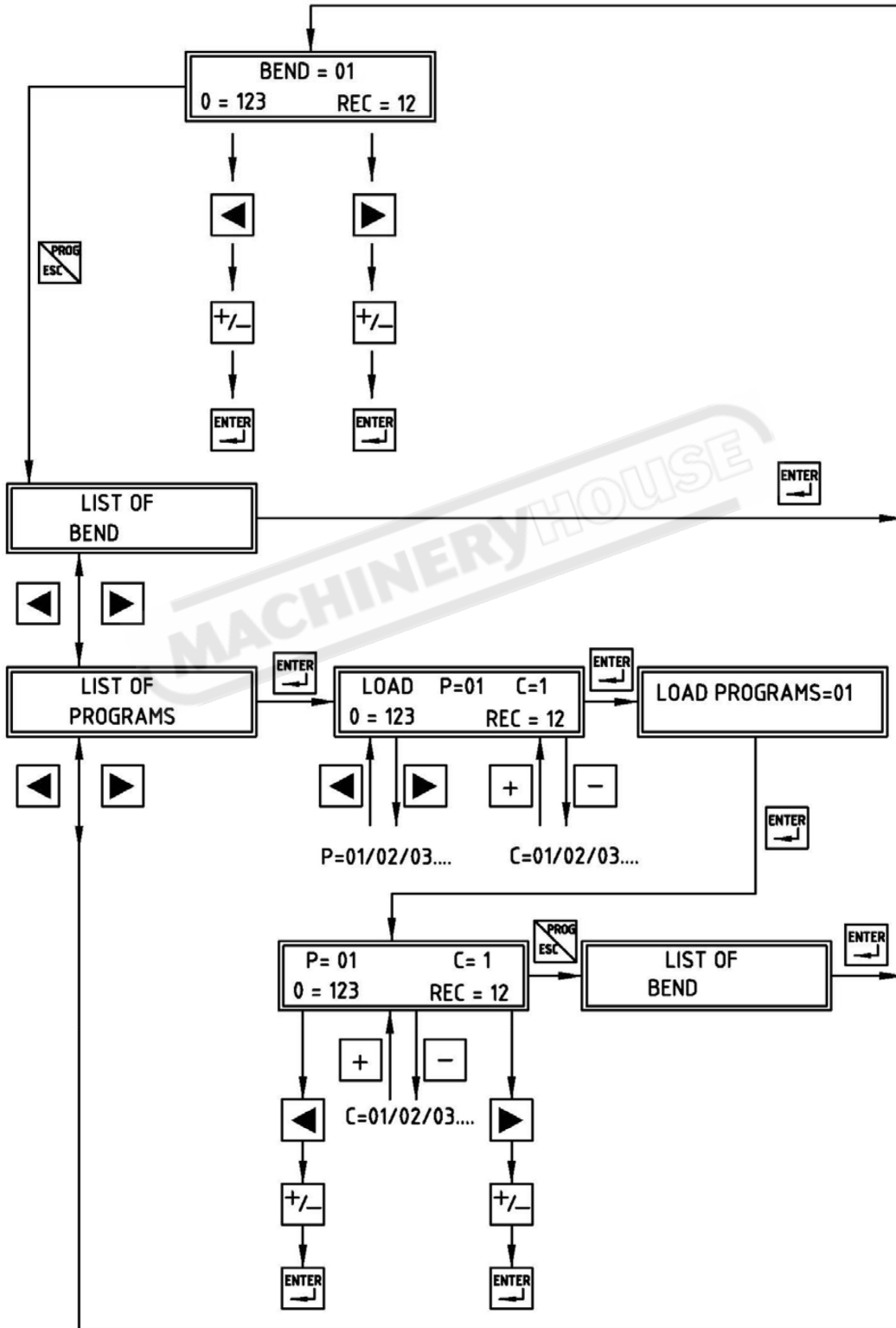

**TB-60 ELECTRICAL DIAGRAM (240VOLT)**

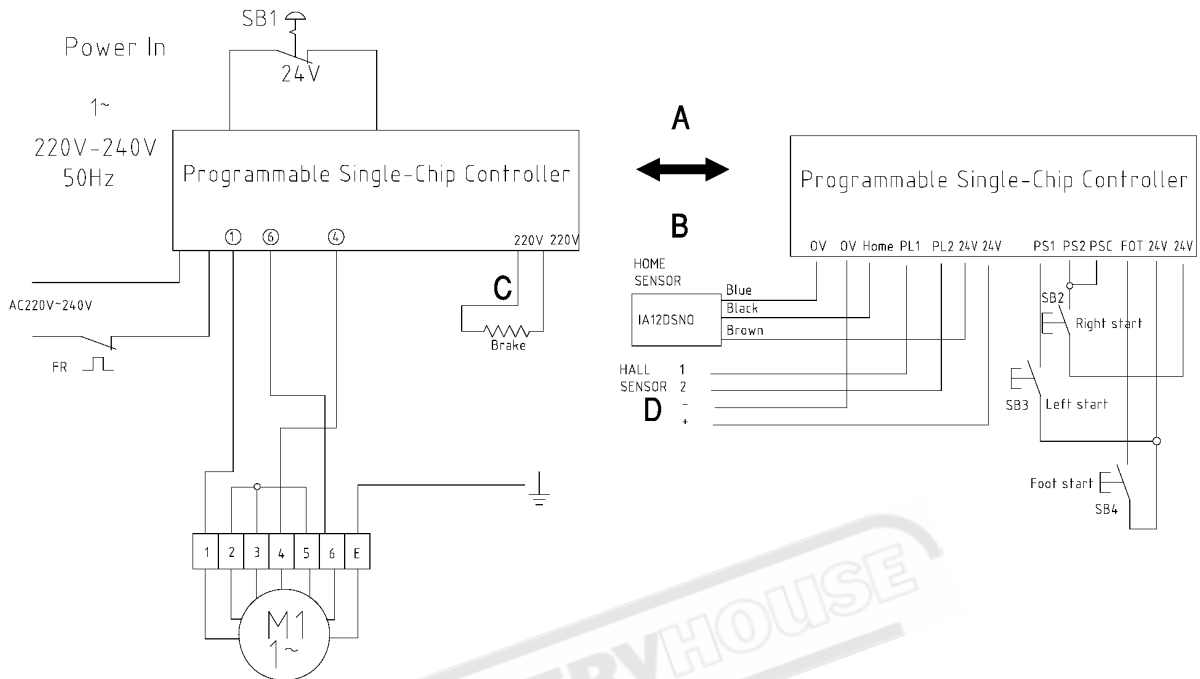

**C** BREAK FOR 220V-240V

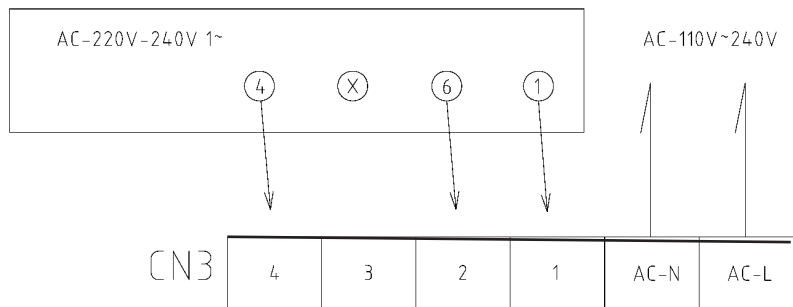
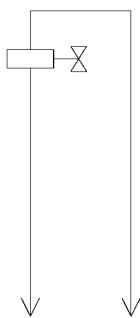

CN2	220V	220V	110V	110V
	BK-	BK+	BK+	BK-

**TB-60 ELECTRICAL DIAGRAM (240VOLT)**

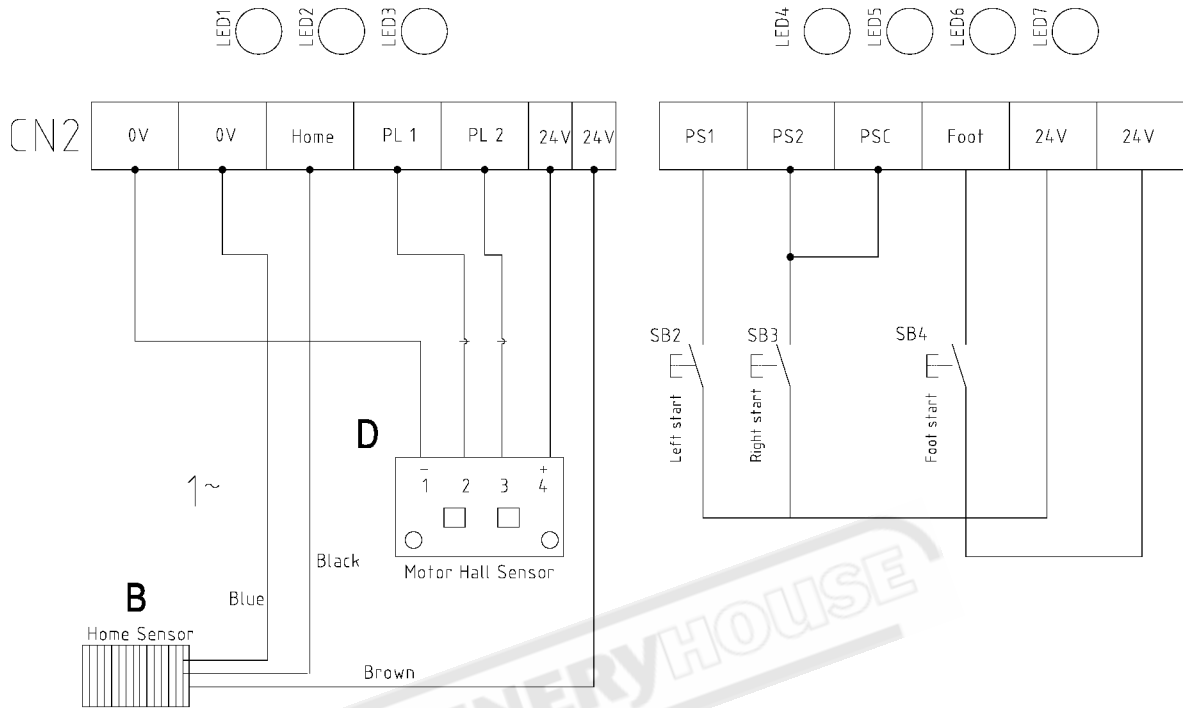

**TB-60 ELECTRICAL PARTS LIST (240VOLT)**

Item	Function	Technical Data	Qty
A	Programmable Single Chip Controller		1
B	Home Sensor	DC 10-30V	1
C	Brake		1
D	Hall Sensor		1
SB1	Emergency Stop Switch	HY57	1
SB2	Right Start	NPB-F-1a	1
SB3	Left Start	NPB-F-1a	1
SB4	Optional Foot Start	Optional	1
M1	Motor for TB-60	1.5hp/230V/50HZ/1P/2P	1
FR	Overload Relay (TB60 only)	8A	1

TB-60 SPARE PARTS DIAGRAM

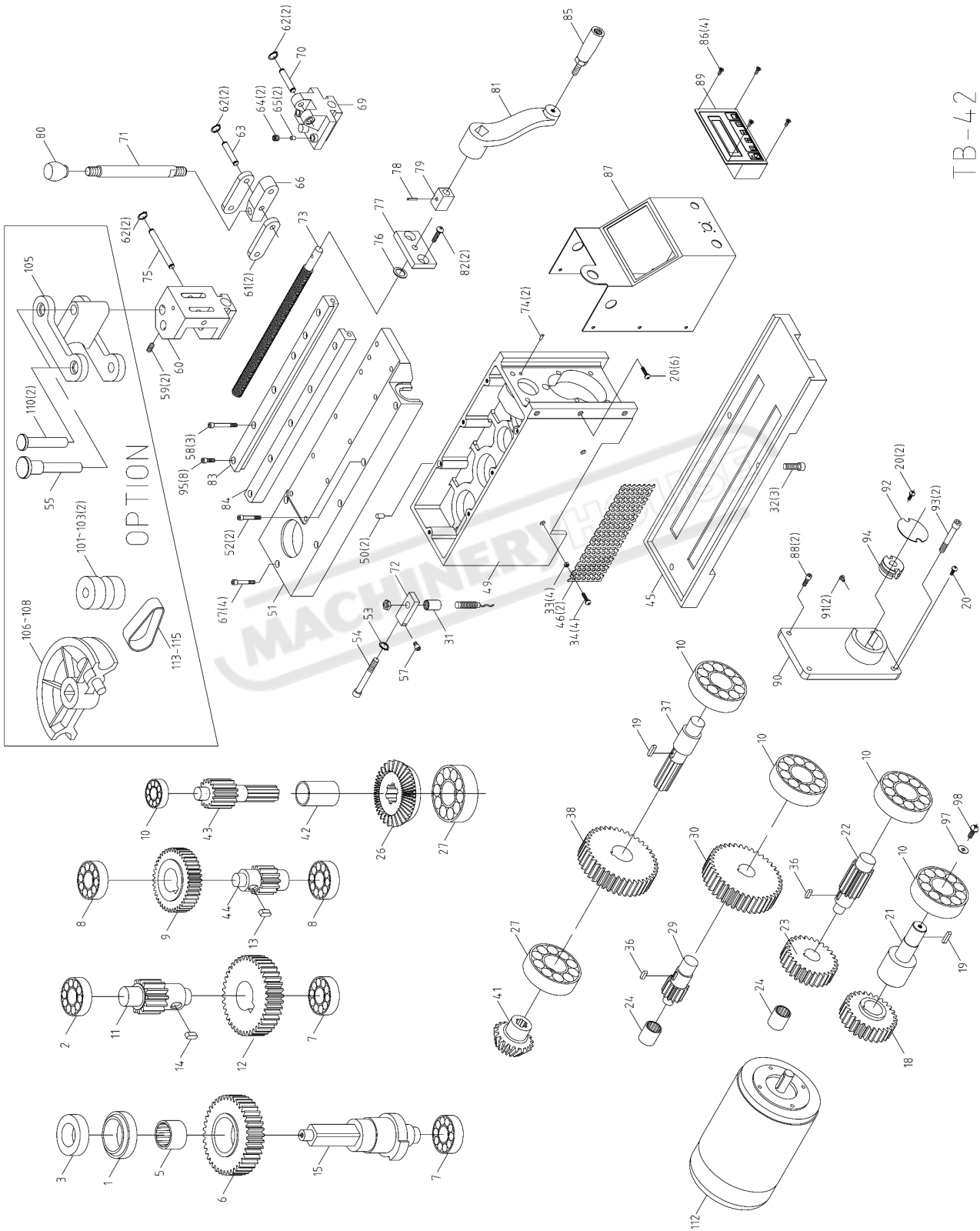

TB-42

**TB-60 SPARE PARTS LIST**

No.	Part No.	Description	Specification	Qty
1	168029	Positioning ring		1
2	CANU206	Bearing	NU206	1
2-1	HS519	Cross Round Head Screw	M5x10L	2
2-2	HW003	Washer	M5	2
3	168030	Outlet shaft's spacer		1
5	CANK6525	Bearing	NK65/25	1
6	168013	Outlet gear		1
7	CA6206ZZ	Bearing	6206ZZ	2
8	CA6204ZZ	Bearing	6204ZZ	2
9	168017	Plate wheel		1
10	CA62022RS	Bearing		5
11	168014	Pinion		1
12	168015	Plate wheel		1
13	168536	Key	8x7x20L	1
14	168535	Key	12x8x20L	1
15	168012	Outlet shaft		1
18	168028	Motor's Pinion		1
19	HK118	Key	5*5*12L	2
20	HT020	Cross Round Head Screw	M5-0.8PX8L	9
21	168027	Motor shaft's nut		1
22	168025	Motor's pinion		1
23	168026	Motor's plate wheel		1
24	CAHK1012	Bearing	HK1012	2
26	168020	Plate wheel		1
27	CA60042RS	Bearing	6004-2RS	2
29	168024	Pinion		1
30	168023	Plate wheel		1
31	168031	Spacer		1
32	HS259	Hex. Socket Head Screw	M10-1.5Px25L	3
33	HN003	Hex. Nut	M5	4
34	HT002	Cross Round Head Screw	M5-0.8Px16L	4
36	HK006	Key	5x5x10L	2
37	168019	Keyed shaft		1
38	168022	Plate wheel		1
41	168021	Bevel pinion		1
42	168033	Spacer		1
43	168018	Outlet pinion		1
44	168016	Pinion		1
45	168001	Reduction box base		1

**TB-60 SPARE PARTS LIST Cont.**

No.	Part No.	Description	Specification	Qty
46	168034	Protection plate		2
49	168003	Reduction box		1
50	168061	Positioning ring		2
51	168002	Box reduction cap		1
52	HS250	Hex. Socket Head Screw	M8x60L	2
53	HCS39	C-Retainer Ring	S8	1
54	168062	Screw		1
55	168036	C/former support pin		1
57	HS332	Hex. Socket Head Screw	M5X6L	1
59	HS413	Hex. Socket Headless Screw	M5x5L	2
60	168011	C/former support		1
61	168038	Action rod		2
62	HCS01	C-Retainer Ring	S10	6
63	168039	Plug rod		1
64	HS430	Hex. Socket Headless Screw	M8x10L	2
65	168739	Friction plate		2
66	168040	Locking rod		1
67	HS248	Carriage Screw	M8x50L	6
69	168005	Quick positioner		1
70	168042	Plug for quick positioner		1
71	168043	Locking lever		1
72	168044	Sensor plate		1
73	168010	Regulation screw		1
74	HP108	Pin	Ø6X12L	2
75	168045	Plug 10x85		1
76	168046	Washer		1
77	168047	Flange regulation screw		1
78	HP031	Spring Pin	Ø6X20L	1
79	168048	Hexagon regulation screw		1
80	290086	Plastic Round Knob		1
81	168060	Action arm		1
82	HT043	Cross Round Head Screw	M10X20L	2
84	HS242	Hex. Socket Head Screw	M8x20L	12
85	6027-1S	Clamp Handle		1
86	HS639	Flat Cross Head Screw	M3X6L	4
87	168051D	Front Cover Plate		1
88	HS244	Hex. Socket Head Screw	M8x30L	2
89	ET2544	Controller	110/220V//1PH	1
89	ET2545	Controller	220/380V//3PH	1

**TB-60 SPARE PARTS LIST Cont.**

No.	Part No.	Description	Specification	Qty
90	168004	Flange		1
91	HS503	Cross Round Head Screw	M3x10L	2
92	168032	Cover		1
93	HS252	Hex. Socket Head Screw	M8x70L	2
94	168065	Magnets flange		1
97	HW016	Washer	φ6.5Xφ18xt1.5mm	1
98	HT003	Cross Round Head Screw	M6-1.0Px10L	1
101	168054	Roll-1	1/2"G (Optional)	2
102	168055	Roll-2	1"G (Optional)	2
103	168056	Roll-3	1 1/4"G (Optional)	2
104	168059	Roll-4	1/4"G (Optional)	2
105	168057	Guide body	(Optional)	1
106	168006	Former-1	1/4"G (Optional)	1
107	168007	Former-2	1/2"G (Optional)	1
108	168008	Former-3	1"G (Optional)	1
109	168009	Former-4	1 1/4"G (Optional)	1
110	168058	C/former support	(Optional)	2
112		Motor	1.5HP/50HZ/220V/1PH	1
113	168067	Ring-1	1/4"G (Optional)	1
114	168068	Ring-2	1/2"G (Optional)	1
115	168069	Ring-3	1"G (Optional)	1
116	168070	Ring-4	1 1/4"G (Optional)	1
117	168264	Handle Rod	(Optional)	1
118	168265	Foot Switch Bracket	(Optional)	1
119	HN006	Hex. Nut	M10 (Optional)	1
120	HW106	Spring Washer	M10 (Optional)	1
121	MET1654	Foot Switch	(Optional)	2
122	HE506	Cross Round Head Screw	M5x10L (Optional)	6
123	HN003	Hex. Nut	M5 (Optional)	6
124	MET2190	Coupler	1/2" (Optional)	1
125	MET2189	Hose	1/2" (Optional)	1
126	168097	Scale	(Optional)	1
127	HH001	Rivet	ØM2x5L (Optional)	2
128	PJNG681505E4	Lable	(Optional)	1



**TB-70 ELECTRICAL DIAGRAM (415VOLT) Cont.**

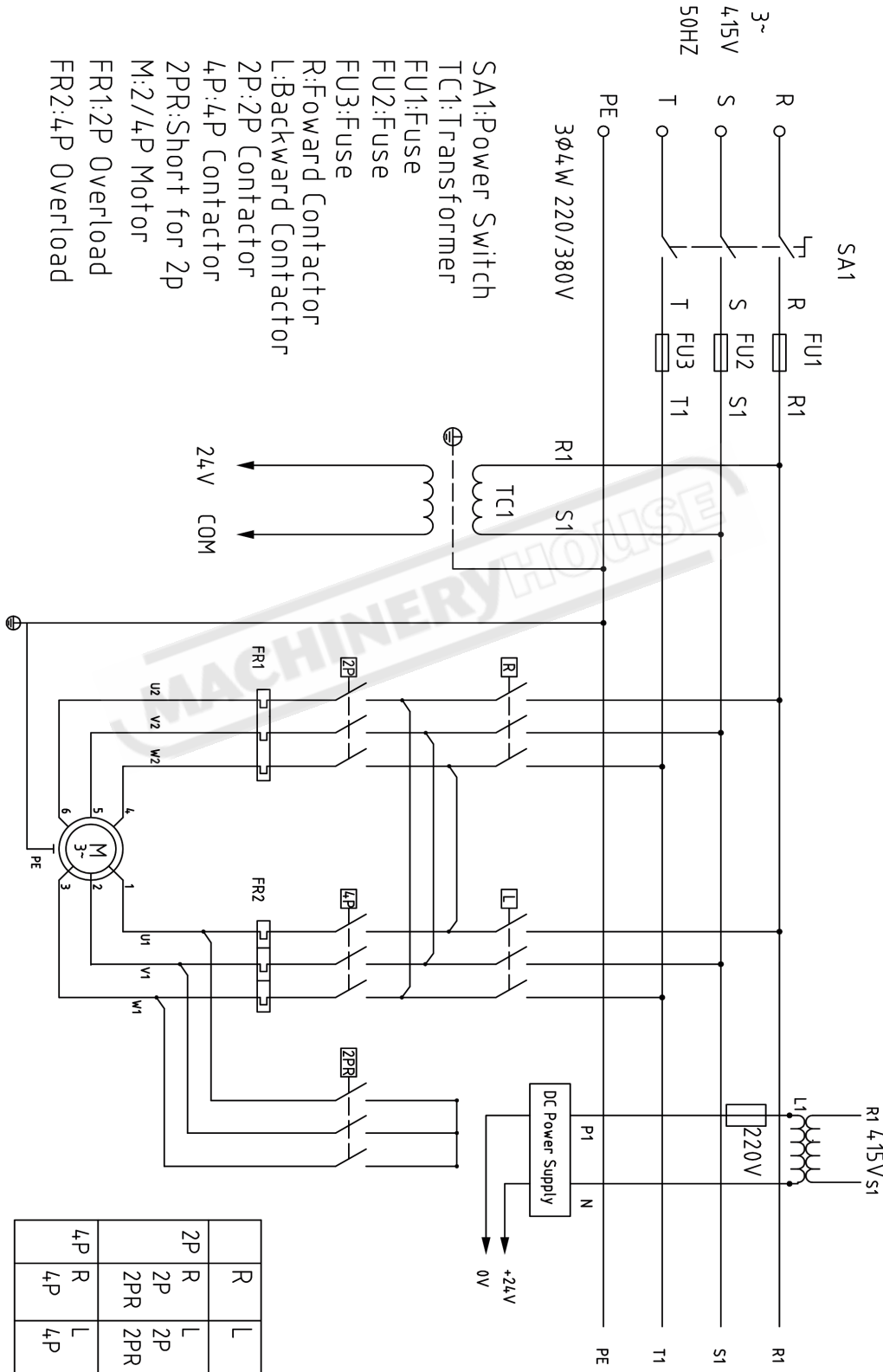

- SA1: Power Switch
- TC1: Transformer
- FU1: Fuse
- FU2: Fuse
- FU3: Fuse
- R: Forward Contactor
- L: Backward Contactor
- 2P: 2P Contactor
- 4P: 4P Contactor
- 2PR: Short for 2P
- M: 2/4P Motor
- FR1: 2P Overload
- FR2: 4P Overload

	R	L
2P	R	L
	2P	2P
	2PR	2PR
4P	R	L
	4P	4P

**TB-70 ELECTRICAL DIAGRAM (415VOLT) Cont.**

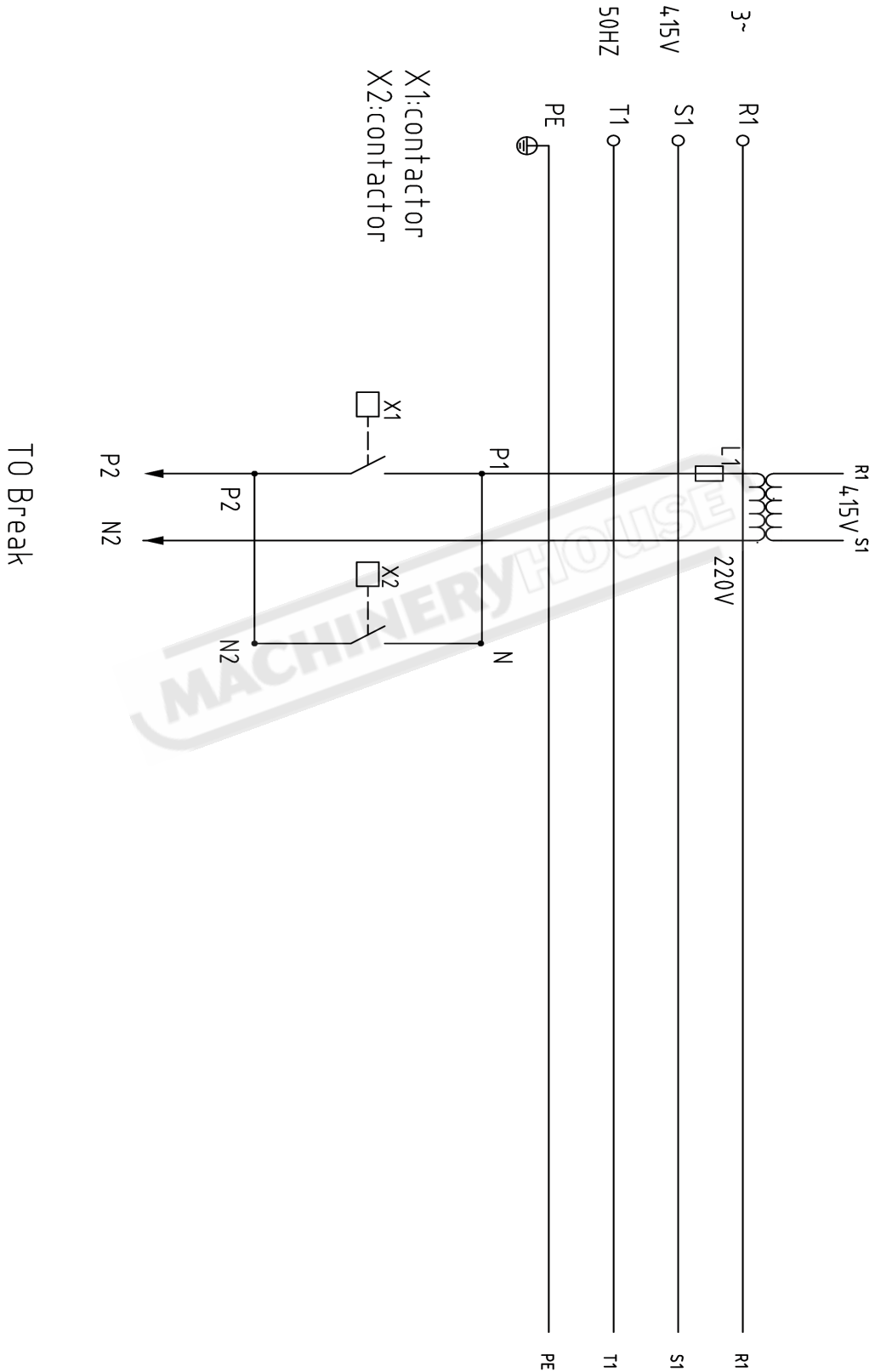

**TB-70 ELECTRICAL DIAGRAM (415VOLT) Cont.**

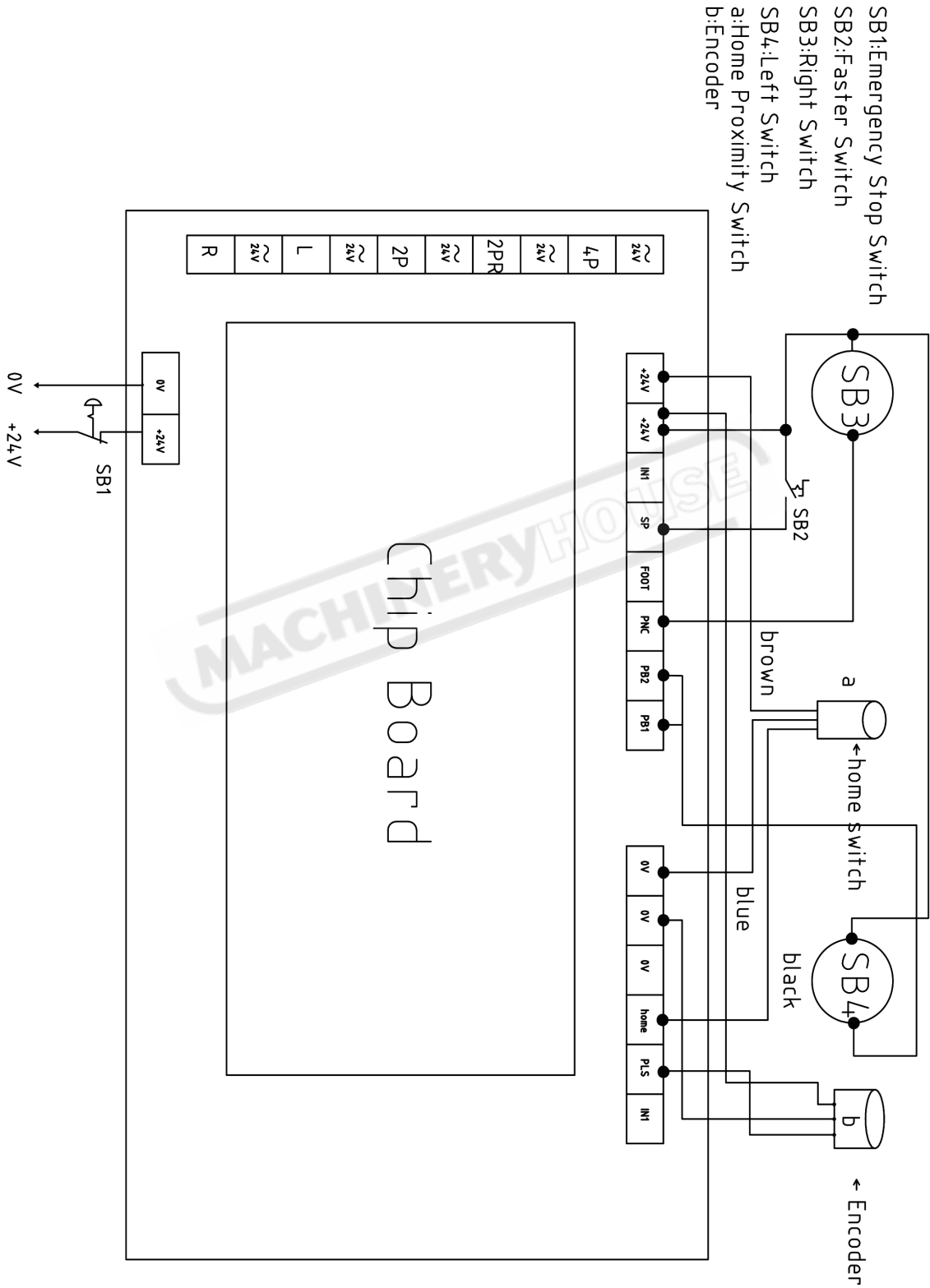

SB1:Emergency Stop Switch  
 SB2:Faster Switch  
 SB3:Right Switch  
 SB4:Left Switch  
 a:Home Proximity Switch  
 b:Encoder

MACHINERYHOUSE.COM.AU

**TB-70 SPARE PARTS DIAGRAM**

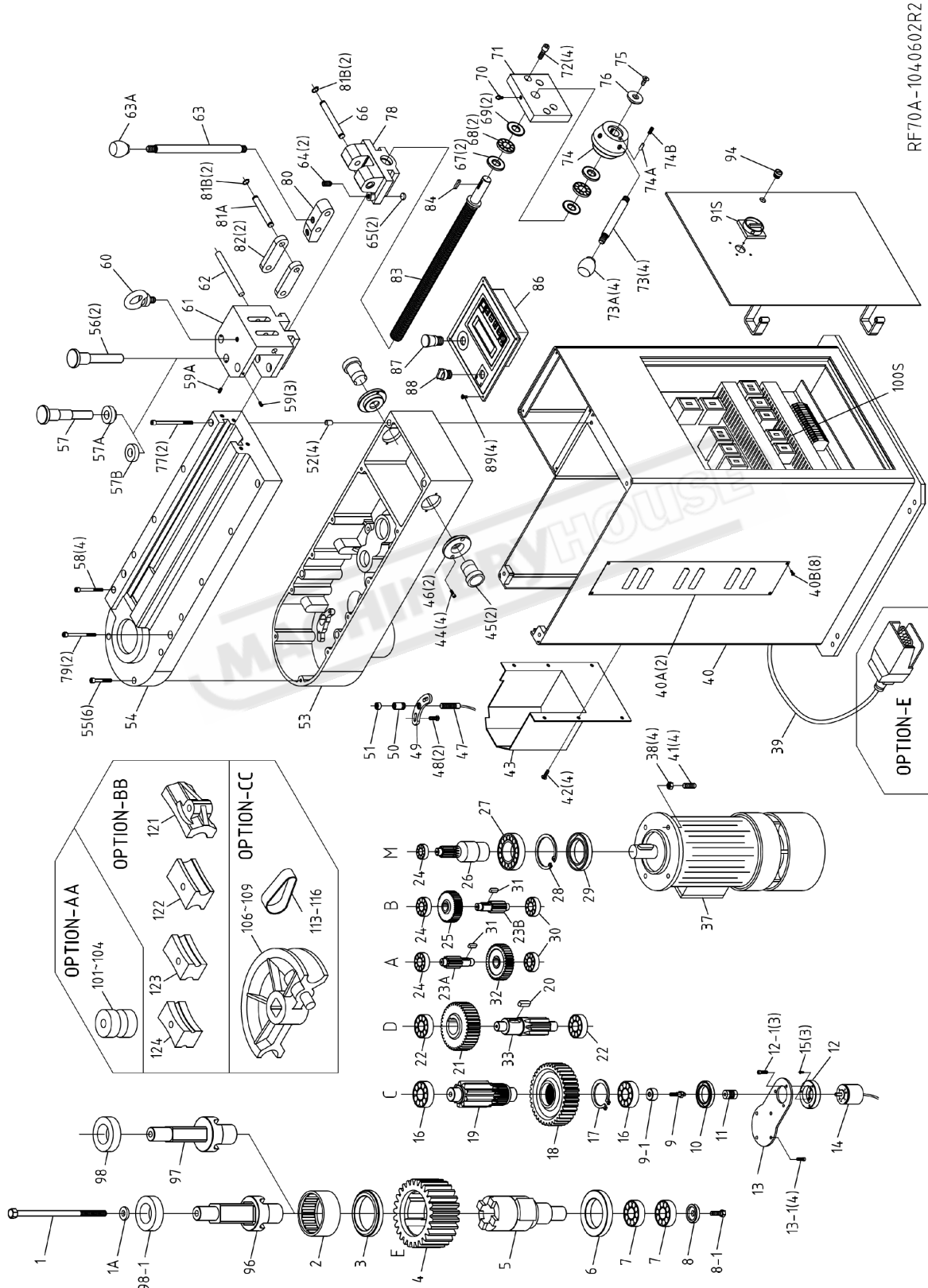

RF70A-1040602R2

**TB-70 SPARE PARTS LIST**

No.	Part No.	Description	Specification	Qty
1	168748	Leadscrew		1
1A	168747	Bushing		1
2	CANK7535	Bearing	NK75/35(92B)	1
3	168718	Shaft Bushing(B)		1
4	168717	Gear		1
5	168715	Power Shaft		1
6	168716	Shaft Bushing(A)		1
7	CA30206J	Tapered Bearing	#30206J	2
8	168730	Washer Ring		1
9	168731	Fixed Bolt		1
10	HG042	Oil Seal	TC40X62X10b	1
11	168770	Connecting shaft		1
12	168750	Connect Plate		1
13	HS230	Hex. Socket Head Screw	M6X20L	2
14	ET2501	Encoder		1
15	HS610	Flat Cross Head Screw	M5X10L	3
16	CANJ2206	Bearing	#NJ2206	2
17	HCS24	C-Retainer Ring	S42	1
18	168722	Gear		1
19	168721	Gear		1
20	HK139	Key	10X8X30L	1
21	168720	Gear		1
22	CANJ2304	Bearing	#NJ2304	2
23A	168723	Gear		1
23B	168725	Gear		1
24	CA6202RS	Bearing	#6202RS	3
25	168726	Gear		1
26	168727	Gear		1
27	CA60082RS	Bearing	#6008-2RS	1
28	HCR09	C-Retainer Ring	R68	1
29	HG043	Oil Seal	TC40X68X10b	1
30	MCA6202ZZ	Bearing	#6202	2
31	HK025	Key	6X6X20L	2
32	168724	Gear		1
33	168719	Gear		1
37	MFV2165-1	Motor		1
38	HN006	Hex. Nut	M10	4
39				1
40	168701	Stand		1

**TB-70 SPARE PARTS LIST Cont.**

No.	Part No.	Description	Specification	Qty
40A	168702	Chip Tray		2
40B	HT026	Cross Round Head Screw	M5X12L	8
40C	168702-1	Vesicant Pad	10X10X1750L	1
41	HS444	Hex. Socket Headless Screw	M10X40L	4
42	HT016	Cross Round Head Screw	M6X12L	4
43	168703	Cover		1
44	HS218	Hex. Socket Head Screw	M5X10L	4
45	MET1276	Push-Button Switch		2
46	168749	Bushing		2
47	ET1641	Sensor		1
48	HS229	Hex. Socket Head Screw	M6X15L	2
49	168765	Connect Plate		1
50	168766	Connecting pipe		1
51	168767	Register Sensor		1
52	168732	Positioning Ring		4
53	168710	Reduction box		1
54	168711	Box reduction cap		1
55	HS250	Hex. Socket Head Screw	M8x60L	6
56	168036	Pin		2
57	168052	Pin		1
57A	168053	Base Broad		1
57B	168041	Interval Ring		1
58	HS324	Hex. Socket Head Screw	M8x90L	4
59	HS462	Hex. Socket Headless Screw	M6X8L	3
59A	HS422	Hex. Socket Headless Screw	M6X10L	1
60	HI413	Ring Bolt	M12	1
61	168709	Fixed Board		1
62	168737	Shaft(C)		1
63	168043	Locking lever		1
63A	290086	Plastic Round Knob		1
64	HS464	Hex. Socket Headless Screw	M12X16L	2
65	168739	Screw rod washer		2
66	168735	Shaft(A)		1
67	CAGS2035	Sheaths	#GS2035	2
68	CANTB2035	Bearing	#NTB2035	2
69	CAAS2035	Sheaths	#AS2035	2
70	HB501	Grease Nipple	PT-1/8"	1
71	168745	Vice Plate		1
72	HS259	Hex. Socket Head Screw	M10X25L	4

**TB-70 SPARE PARTS LIST Cont.**

No.	Part No.	Description	Specification	Qty
73	168744	Handle Rod		4
73A	290086	Plastic Round Knob		4
74	168743	Handle Body		1
74A	168741	Shaft Block		1
74B	HS434	Hex. Socket Headless Screw	M8X30L	1
75	HS619	Flat Cross Head Screw	M8X20L	1
76	168742	Chunk		1
77	HS367	Hex. Socket Head Screw	M10X190L	2
78	168708	Quick Positioner		1
79	HS368	Hex. Socket Head Screw	M10X160L	2
80	168740	Shaft Block		1
81A	168736	Shaft(B)		1
81B	HCS02	C-Retainer Ring	S12	4
82	168738	Shaft Plate		2
83	168746	Leadscrew		1
84	HK009	Key	5X5X25L	1
86	168764	Name Plate		1
86-1	ET2557	Controller	Single Bending	1
86-1	ET2557-1	Controller	Multiple Bending	1
87	MET1245	Emergency Switch		1
88	MET1222	Selector Switch		1
89	HT026	Cross Round Head Screw	M5X12L	4
91S	MET1732	Power Switch		1
94	168777	Key Lock		1
96	168707-1	Output shaft(42)		1
97	168707	Output shaft(32)		1
98	168030A	Interval Ring		1
98-1	168706	Interval Ring	Ø54	1
100S		Electronic Control Module		1
101	168054	D213 Roll	1/2"G (Optional)	2
102	168055	D337 Roll	1"G (Optional)	2
103	168056	D423Roll	1 1/4"G (Optional)	2
104	168773	D483 Roll	1 1/2"G (Optional)	2
106	168771	D483 Former	1 1/2"G (Optional)	1
107	168007	D213 Former	1/2"G (Optional)	1
108	168008	D337 Former	1"G (Optional)	1
109	168009	D423 Former	1 1/4"G (Optional)	1
113	168068	Ring-2	1/2"G (Optional)	1
114	168069	Ring-3	1"G (Optional)	1

**TB-70 SPARE PARTS LIST Cont.**

No.	Part No.	Description	Specification	Qty
115	168070	Ring-4	1 1/4"G (Optional)	1
116	168089	D51 Ring	D51/1 1/2"G (Optional)	1
121	168755	Gib(A)	1 1/4"G(Ø42.7) (Optional)	1
122	168756	Gib(B)	1"G(Ø34)X3/4"G(Ø27.2) (Optional)	1
123	168757	Gib(C)	1/2"G(Ø21.7)X3/8"G(Ø17.3) (Optional)	1
124	168758	Gib(D)	1/4"G(Ø13.8)X1/8"G(Ø10.5) (Optional)	1

MACHINERYHOUSE

# WARNING

## General Machinery Safety Instructions

---

Machinery House  
requires you to read this entire Manual before using this machine.

- 1. Read the entire Manual before starting machinery.** Machinery may cause serious injury if not correctly used.
- 2. Always use correct hearing protection when operating machinery.** Machinery noise may cause permanent hearing damage.
- 3. Machinery must never be used when tired, or under the influence of drugs or alcohol.** When running machinery you must be alert at all times.
- 4. Wear correct Clothing.** At all times remove all loose clothing, necklaces, rings, jewelry, etc. Long hair must be contained in a hair net. Non-slip protective footwear must be worn.
- 5. Always wear correct respirators around fumes or dust when operating machinery.** Machinery fumes & dust can cause serious respiratory illness. Dust extractors must be used where applicable.
- 6. Always wear correct safety glasses.** When machining you must use the correct eye protection to prevent injuring your eyes.
- 7. Keep work clean and make sure you have good lighting.** Cluttered and dark shadows may cause accidents.
- 8. Personnel must be properly trained or well supervised when operating machinery.** Make sure you have clear and safe understanding of the machine you are operating.
- 9. Keep children and visitors away.** Make sure children and visitors are at a safe distance for you work area.
- 10. Keep your workshop childproof.** Use padlocks, Turn off master power switches and remove start switch keys.
- 11. Never leave machine unattended.** Turn power off and wait till machine has come to a complete stop before leaving the machine unattended.
- 12. Make a safe working environment.** Do not use machine in a damp, wet area, or where flammable or noxious fumes may exist.
- 13. Disconnect main power before service machine.** Make sure power switch is in the off position before re-connecting.
- 14. Use correct amperage extension cords.** Undersized extension cords overheat and lose power. Replace extension cords if they become damaged.
- 15. Keep machine well maintained.** Keep blades sharp and clean for best and safest performance. Follow instructions when lubricating and changing accessories.
- 16. Keep machine well guarded.** Make sure guards on machine are in place and are all working correctly.
- 17. Do not overreach.** Keep proper footing and balance at all times.
- 18. Secure workpiece.** Use clamps or a vice to hold the workpiece where practical. Keeping the workpiece secure will free up your hand to operate the machine and will protect hand from injury.
- 19. Check machine over before operating.** Check machine for damaged parts, loose bolts, Keys and wrenches left on machine and any other conditions that may effect the machines operation. Repair and replace damaged parts.
- 20. Use recommended accessories.** Refer to instruction manual or ask correct service officer when using accessories. The use of improper accessories may cause the risk of injury.
- 21. Do not force machinery.** Work at the speed and capacity at which the machine or accessory was designed.
- 22. Use correct lifting practice.** Always use the correct lifting methods when using machinery. Incorrect lifting methods can cause serious injury.
- 23. Lock mobile bases.** Make sure any mobile bases are locked before using machine.
- 24. Allergic reactions.** Certain metal shavings and cutting fluids may cause an allergic reaction in people and animals, especially when cutting as the fumes can be inhaled. Make sure you know what type of metal and cutting fluid you will be exposed to and how to avoid contamination.
- 25. Call for help.** If at any time you experience difficulties, stop the machine and call you nearest branch service department for help.

# WARNING

## Elec/Mech Pipe/Tube Bender Safety Instructions

---

Machinery House  
requires you to read this entire Manual before using this machine.

- 1. Maintenance.** Make sure the Pipe/Tube Bender is turned off and disconnect from the main power supply and make sure all moving parts have come to a complete stop before any inspection, adjustment or maintenance is carried out.
- 2. Pipe Bender Condition.** Pipe/Tube Bender must be maintained for a proper working condition. Never operate a Pipe/Tube Bender that has damaged or worn parts. Scheduled routine maintenance should be performed on a scheduled basis. Check frame, rollers, springs & formers for cracks or damage. Replace if necessary.
- 3. Former Condition.** Never operate a Pipe/Tube Bender with damaged or badly worn Formers. Replace if required.
- 4. Hand Hazard.** Keep hands away from the Pipe/Tube Bender, under any circumstances, while the machine is in operation mode. Serious injury can occur.
- 5. Gloves & Glasses.** Always wear leather gloves and approved safety glasses when using this machine.
- 6. Work area hazards.** Keep the area around the Pipe/Tube Bender clean from oil, tools, objects & chips. Pay attention to other persons in the area and know what is going on around the area to ensure unintended accidents.
- 7. Guards.** Do not operate Pipe/Tube Bender without the correct guards in place. Necessary guards protect you from injuries by worm-type gearbox and other gears. The only other area which needs to be carefully monitored during use is the rotational area of the formers.
- 8. Understand the machines controls.** Make sure you understand the use and operation of all controls.
- 9. Overloading Pipe/Tube Bender.** Do not over load the machine by using material which exceeds the rated capacity.
- 10. Avoiding Entanglement.** Pipe/Tube Bender guards must be used at all times. Tie up long hair and use the correct hair nets to avoid any entanglement with the Pipe/Tube Benders moving parts.
- 11. Trained Operator.** This machine must be operated by authorized and trained personnel.
- 12. Power outage.** In the event of a power failure during use of the machine, turn off all switches to avoid possible sudden start up once power is restored.
- 13. Warning Labels.** Take note of any warning labels on the machine and do not remove them.
- 14. Material Hazard.** Do not bend plastics or other objects that could shatter. Serious injury can occur.
- 15. Stopping the Former.** Do not stop or slow the former with your hand or workpiece. Allow the machine to stop on its own.
- 16. Secure Pipe/Tube Bender.** Make sure you bolt the machine down so it is secure when in operation.
- 17. Pinching.** Prevent pinching by releasing pressure on the workpiece when not in use.
- 18. Emergency stop.** Use the emergency stop button in case of any emergency.
- 19. Hearing protection and hazards.** Always wear hearing protection as noise generated from machine and workpiece can cause permanent hearing loss over time.
- 20. Call for help.** If at any time you experience difficulties, stop the machine and call you nearest branch service department for help.

## PLANT SAFETY PROGRAM

### **NEW MACHINERY HAZARD IDENTIFICATION, ASSESSMENT & CONTROL**

#### **Electric/Mechanical Pipe/Tube Benders**

Developed in Co-operation Between A.W.I.S.A and Australia Chamber of Manufactures  
This program is based upon the Safe Work Australia, Code of Practice - Managing Risks of Plant in the Workplace ( WHSA 2011 No10 )

Item No.	Hazard Identification	Hazard Assessment	Risk Control Strategies <small>(Recommended for Purchase / Buyer / User)</small>
B	CRUSHING	HIGH	Do not exceed maximum capacity. Check equipment for damage prior to use. Wear safety boots. Never put any part of your body between moving formers and material. Always support material properly.
C	CUTTING, STABBING OR PUNCTURING	MEDIUM	Use equipment in the correct manner as to avoid parts being ejected out under pressure.
E	STRIKING	MEDIUM	Use equipment in the correct manner as to avoid parts being ejected out under pressure. Ensure correct formers are used for the correct job.
H	ELECTRICAL	MEDIUM	All electrical enclosures should only be opened with a tool that is not to be kept with the machine. Machine should be installed & checked by a Licensed Electrician.
O	OTHER HAZARDS, NOISE.	LOW	Wear hearing protection as required.
Plant Safety Program to be read in conjunction with manufactures instructions			



[www.machineryhouse.com.au](http://www.machineryhouse.com.au)



[www.machineryhouse.co.nz](http://www.machineryhouse.co.nz)

Authorised and signed by:

Safety officer:

Manager:

Revised Date: 12th March 2012